

Nema 23

2 phase 1.8° step angle
 hybrid stepping motor

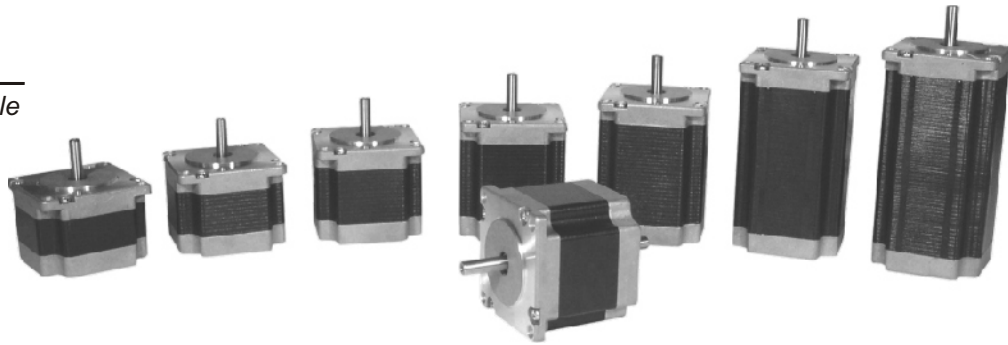

Specifications:

Model	Holding Torque (Nm)	Phase current (A)	Rotor Inertia (g/cm ²)	Motor Length L max (mm)	Detent Torque (Nm)	Phase Resistance (ohm)	Phase Inductance (mH)	Lead Wire (No)	Motor Weight (Kg)	Note
M1233011	0.55	0.62	150	41	0.025	13	24.5	4	0.47	
M1233012	0.55	2.0	150	41	0.025	1.2	2.4	4	0.47	
M1233021	0.80	0.62	190	45	0.028	12	29	4	0.52	
M1233022	0.80	2.5	190	45	0.028	1.0	2.2	4	0.52	
M1233031	1.00	0.62	190	51	0.028	13.4	33	4	0.62	
M1233032	1.10	2.5	190	51	0.028	1.15	3.3	4	0.62	
M1233041	1.10	4.2	280	56	0.035	0.4	1.2	4	0.68	
M1233051	1.40	3.0	380	64	0.05	0.8	2.4	4	0.85	
M1233061	1.80	3.0	440	76	0.06	1.0	3.54	4	1.05	8 mm shaft available
M1233062	1.80	4.2	440	76	0.06	0.55	1.8	4	1.05	
M1233070	3.00	4.2	680	100	0.1	0.8	3.0	4	1.5	
M1233071	3.00	6.0	680	100	0.1	0.4	1.5	4	1.5	
M1233081	3.40	6.0	800	112	0.12	0.44	1.9	4	1.7	

Double shaft and custom windings available

Mechanical Dimensions:
 Unit: mm

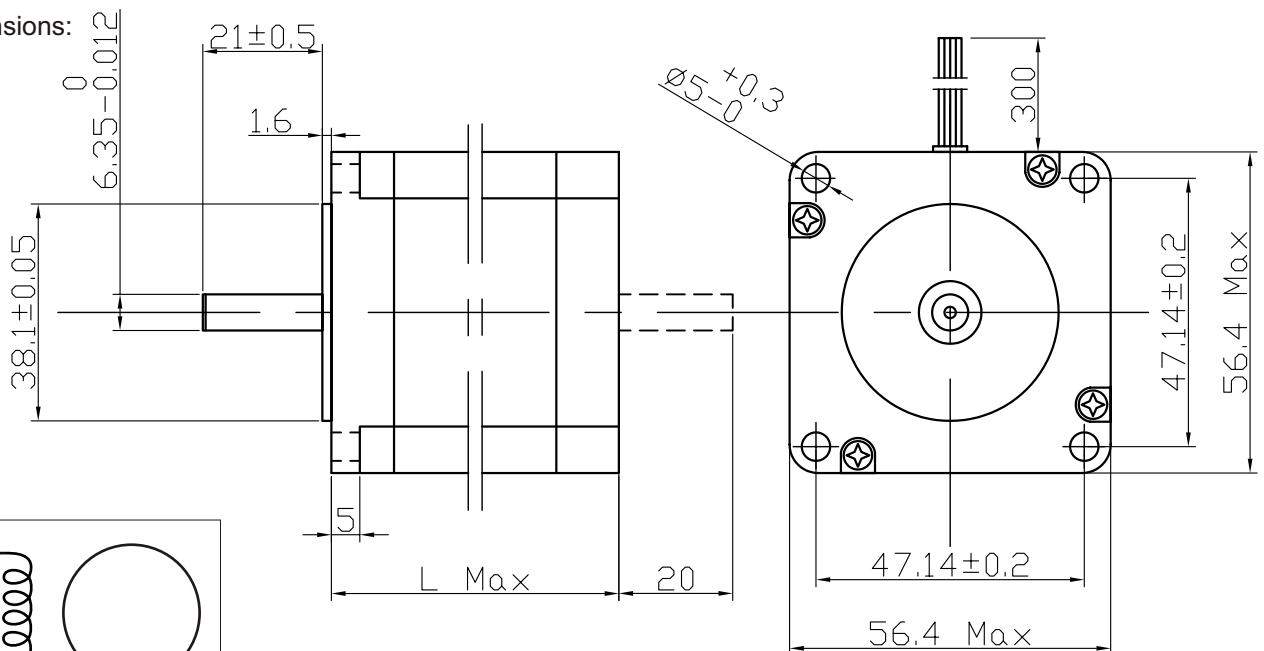

Wiring Diagram:

