

Datasheet LSN Motors

V 2.3 / 04-2012

Size Q50 to Q190





Brushless Servomotors

LSN-050-xxxxSeries

U_{dc} = 320 / 560 VDC

General Description:

Compact Design
Rare Earth Magnets
Resolver Feedback
Intercontec-Connectors

Options:

Holding Brake, different Encoders,
Shaft Keyway DIN 6885, UL, ATEX,
spec. Shaft / Flange / Housing,
Gearbox, Flying Leads, etc...

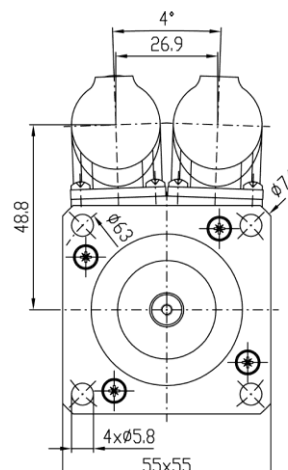
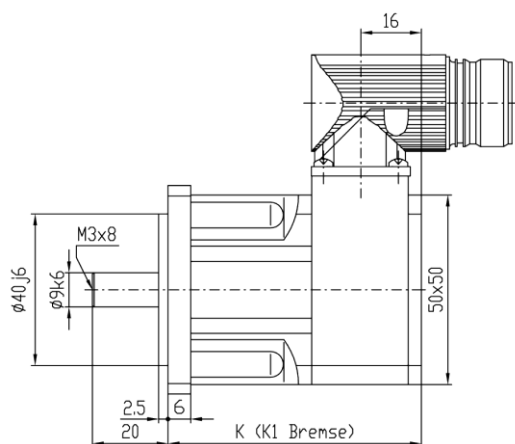

Parameters			LSN-050-0028		LSN-050-0054		LSN-050-0075		LSN-050-0095	
DC Bus Voltage	U _{dc}	V	320	560	320	560	320	560	320	560
Rated Torque	M _N	Nm	0,25		0,48		0,68		0,85	
Rated AC Current	I _N	A	0,96	0,96	1,12	0,9	1,48	0,83	1,7	1,07
Stall Torque	M ₀	Nm	0,28		0,54		0,75		0,95	
Stall Current	I ₀	A	0,97	0,97	1,17	0,93	1,54	0,86	1,82	1,15
Peak Torque	M _{max}	Nm	1,1		2,2		3,0		3,8	
Peak AC Current	I _{max}	A	4,5	4,5	5,4	4,3	7,1	3,9	8,4	5,3
Rated Speed*	n _N	min ⁻¹	4500							
Max. Mech. Speed	n _{max}	min ⁻¹	12000							
Torque Constant	K _T	Nm/A	0,29	0,29	0,46	0,58	0,49	0,88	0,52	0,83
Voltage Constant	K _E	V/1000	17,5	17,5	28	35	29,5	53	31,5	50
Resistance Ph-Ph	R _{Ph}	Ω	28,3	28,3	25,9	41,1	17,0	54,0	13,1	33,6
Inductance Ph-Ph	L _{Ph}	mH	28,4	28,4	32,3	51,0	22,7	72,0	19,0	48,5
El. Time Constant	T _{el}	ms	1,0	1,0	1,2	1,2	1,3	1,3	1,45	1,45
Therm. Constant	T _{th}	min	10		12		15		18	
Inertia	J	kgcm ²	0,05		0,07		0,09		0,11	
Rated Brake Torque	M _{Br}	Nm	2,0							
Weight w/o brake	m	kg	0,76		0,93		1,1		1,27	
Weight with brake	m _{Br}	kg	1,20		1,37		1,54		1,71	
Length w/o brake	K	mm	67		82		97		112	
Length with brake	K1	mm	105		120		135		150	

*Windings for different rated speeds are available; parameter tolerance +/-10%

Protection Class	IP64, optional IP65 or IP67
Electrical Connections	Intercontec-Connectors (2 pcs)
Thermal Protection	PTC, optional thermal switch (normally closed type) tripping out at 140°C, KTY or NTC
Rated Parameters	Acc. to EN 60034-1, T _{Ambient} = 40°C, T _{Rise} = 110 K, Flange Temperature ≤ 65°C
Motor Controller	Standard winding designed for power supply U _{cc} = 320 or 560 VDC, different execution optional
Flange/Shaft	Acc. To DIN 42955N, optional R



Brushless Servomotors

LSN-074-xxxx Series

U_{dc} = 320 / 560 VDC

General Description:

Compact Design
Rare Earth Magnets
Resolver Feedback
Intercontec-Connectors

Options:

Holding Brake, different Encoders,
Shaft Keyway DIN 6885, UL, ATEX,
spec. Shaft / Flange / Housing,
Gearbox, Flying Leads, etc...

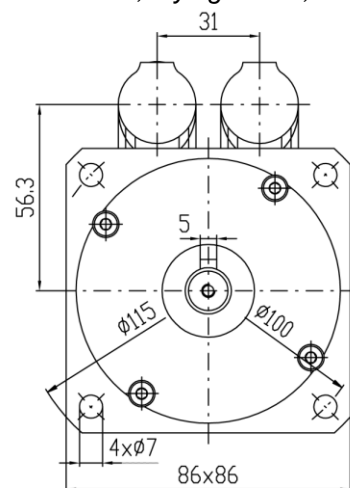
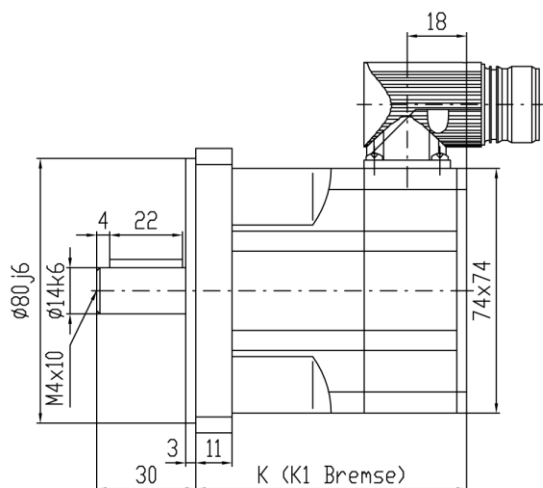

Parameters			LSN-074-0115		LSN-074-0205		LSN-074-0350		LSN-074-0480	
DC Bus Voltage	U _{dc}	V	320	560	320	560	320	560	320	560
Rated Torque	M _N	Nm	1,13		1,90		3,0		3,7	
Rated AC Current	I _N	A	2,3	1,3	3,1	1,7	4,3	2,4	4,5	2,6
Stall Torque	M ₀	Nm	1,15		2,05		3,5		4,8	
Stall Current	I ₀	A	2,0	1,1	2,8	1,6	4,2	2,4	4,8	2,8
Peak Torque	M _{max}	Nm	3,5		6,2		10,5		14,4	
Peak AC Current	I _{max}	A	9,2	5,0	12,7	7,2	19,4	10,9	17,3	9,9
Rated Speed*	n _N	min ⁻¹	3000							
Max. Mech. Speed	n _{max}	min ⁻¹	12000							
Torque Constant	K _T	Nm/A	0,57	1,04	0,74	1,31	0,83	1,47	0,99	1,74
Voltage Constant	K _E	V/1000	34,5	63	44,5	79	50	89	60	105
Resistance Ph-Ph	R _{Ph}	Ω	8,4	27,8	5,4	17,3	2,8	8,9	2,5	7,7
Inductance Ph-Ph	L _{Ph}	mH	18,0	59,3	13,3	42,4	8,1	25,5	7,5	23,5
El. Time Constant	T _{el}	ms	2,1	2,1	2,5	2,5	2,9	2,9	3,0	3,1
Therm. Constant	T _{th}	min	21		23		27		30	
Inertia	J	kgcm ²	0,31		0,55		1,04		1,52	
Rated Brake Torque	M _{Br}	Nm	4,5							
Weight w/o brake	m	kg	1,5		2,0		2,9		3,8	
Weight with brake	m _{Br}	kg	2,0		2,5		3,4		4,3	
Length w/o brake	K	mm	82		100		136		172	
Length with brake	K1	mm	120		138		174		210	

*Windings for different rated speeds are available; parameter tolerance +/-10%

Protection Class	IP64, optional IP65 or IP67
Electrical Connections	Intercontec-Connectors (2 pcs)
Thermal Protection	PTC, optional thermal switch (normally closed type) tripping out at 140°C, KTY or NTC
Rated Parameters	Acc. to EN 60034-1, T _{Ambient} = 40°C, T _{Rise} = 110 K, Flange Temperature ≤ 65°C
Motor Controller	Standard winding designed for power supply U _{cc} = 320 or 560 VDC, different execution optional
Flange/Shaft	Acc. To DIN 42955N, optional R

Brushless Servomotors

LSN-097-xxxx Series

U_{dc} = 320 / 560 VDC



General Description:

Compact Design
Rare Earth Magnets
Resolver Feedback
Intercontec-Connectors

Options:

Holding Brake, different Encoders,
Shaft Keyway DIN 6885, UL, ATEX,
spec. Shaft / Flange / Housing,
Gearbox, Flying Leads, etc...

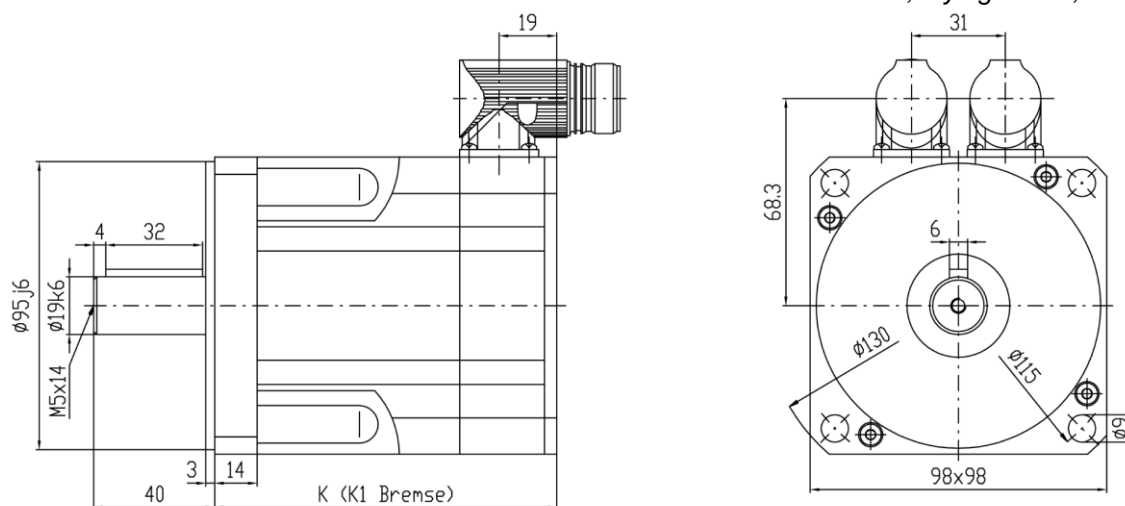

Parameters			LSN-097-0510		LSN-097-0750		LSN-097-0960		LSN-097-1130	
DC Bus Voltage	U _{dc}	V	320	560	320	320	320	320	320	560
Rated Torque	M _N	Nm	4,2		6,1		7,7		8,8	
Rated AC Current	I _N	A	7,0	3,9	8,8	5,1	10,8	6,0	10,7	6,9
Stall Torque	M ₀	Nm	5,1		7,5		9,6		11,3	
Stall Current	I ₀	A	6,8	3,8	8,9	5,2	10,7	6,0	11,0	7,1
Peak Torque	M _{max}	Nm	15,3		22,5		28,8		34	
Peak AC Current	I _{max}	A	31,0	17,4	40,7	23,8	49,2	27,4	41	27
Rated Speed*	n _N	min ⁻¹	3000							
Max. Mech. Speed	n _{max}	min ⁻¹	9000							
Torque Constant	K _T	Nm/A	0,75	1,34	0,84	1,44	0,89	1,6	1,03	1,59
Voltage Constant	K _E	V/1000	45,5	81	51	87	54	97	62	96
Resistance Ph-Ph	R _{Ph}	Ω	1,24	4,0	0,79	2,29	0,62	2,0	0,61	1,49
Inductance Ph-Ph	L _{Ph}	mH	6,8	21,7	4,8	13,5	3,6	11,9	3,8	9,1
El. Time Constant	T _{el}	ms	5,5	5,5	6,1	5,9	5,8	6,0	6,2	6,1
Therm. Constant	T _{th}	min	25		30		35		40	
Inertia	J	kgcm ²	2,04		3,26		4,49		5,70	
Rated Brake Torque	M _{Br}	Nm	9,0							
Weight w/o brake	m	kg	3,8		5,1		6,4		7,7	
Weight with brake	m _{Br}	kg	4,6		5,9		7,2		8,5	
Length w/o brake	K	mm	113		143		173		203	
Length with brake	K1	mm	154		184		214		244	

*Windings for different rated speeds are available; parameter tolerance +/-10%; **N4-1130-30-320 preliminary Data!

Protection Class	IP64, optional IP65 or IP67
Electrical Connections	Intercontec-Connectors (2 pcs)
Thermal Protection	PTC, optional thermal switch (normally closed type) tripping out at 140°C, KTY or NTC
Rated Parameters	Acc. to EN 60034-1, T _{Ambient} = 40°C, T _{Rise} = 110 K, Flange Temperature ≤ 65°C
Motor Controller	Standard winding designed for power supply U _{cc} = 320 or 560 VDC, different execution optional
Flange/Shaft	Acc. To DIN 42955N, optional R



Brushless Servomotors LSN127-xxxx Series

U_{dc} = 320 / 560 VDC

General Description:

Compact Design
Rare Earth Magnets
Resolver Feedback
Intercontec-Connectors

Options:

Holding Brake, different Encoders,
Shaft Keyway DIN 6885, UL, ATEX,
spec. Shaft / Flange / Housing,
Gearbox, Flying Leads, etc...

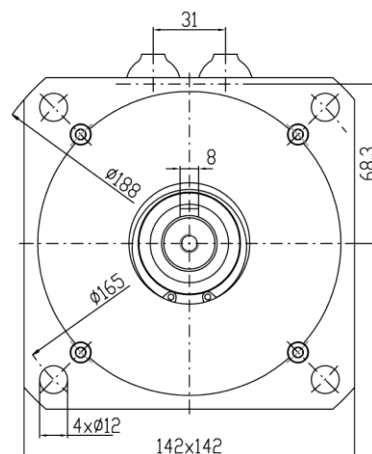
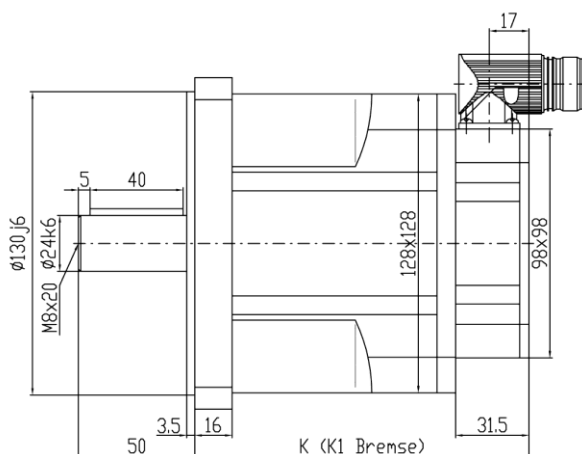

Parameters			LSN-127-1200		LSN-127-1600		LSN-127-2000		LSN-127-2400	
DC Bus Voltage	U _{dc}	V	320	560	320	560	320	560	320	560
Rated Torque	M _N	Nm	10,5		13,8		17,5	16	22	20
Rated AC Current	I _N	A	14,7	8,3	17,0	9,9	16,4	11,5	16,4	14,1
Stall Torque	M ₀	Nm	12		16		20		24	
Stall Current	I ₀	A	14,2	8,0	17,3	10,1	16,1	11,6	15,4	13,8
Peak Torque	M _{max}	Nm	36		48		60		72	
Peak AC Current	I _{max}	A	53	29	61	36	55	40	53	47
Rated Speed*	n _N	min ⁻¹	3000		3000	3000	2000	3000	2000	3000
Max. Mech. Speed	n _{max}	min ⁻¹	9000							
Torque Constant	K _T	Nm/A	0,84	1,51	0,93	1,59	1,24	1,72	1,55	1,74
Voltage Constant	K _E	V/1000	51	91	56	96	75	104	94	105
Resistance Ph-Ph	R _{Ph}	Ω	0,42	1,33	0,30	0,88	0,37	0,72	0,45	0,56
Inductance Ph-Ph	L _{Ph}	mH	3,4	10,9	2,5	7,5	3,3	6,3	4,1	4,9
El. Time Constant	T _{el}	ms	8,1	8,2	8,4	8,5	8,8	8,8	9,0	8,8
Therm. Constant	T _{th}	min	45		55		65		75	
Inertia	J	kgcm ²	9,6		13,3		17,1		20,8	
Rated Brake Torque	M _{Br}	Nm	18							
Weight w/o brake	m	kg	7,5		9,5		11,5		13,5	
Weight with brake	m _{Br}	kg	8,6		10,6		12,6		14,6	
Length w/o brake	K	mm	143,5		173,5		203,5		233,5	
Length with brake	K1	mm	179,5		209,5		239,5		269,5	

*Windings for different rated speeds are available; parameter tolerance +/-10%

Protection Class	IP64, optional IP65 or IP67
Electrical Connections	Intercontec-Connectors (2 pcs)
Thermal Protection	PTC, optional thermal switch (normally closed type) tripping out at 140°C, KTY or NTC
Rated Parameters	Acc. to EN 60034-1, T _{Ambient} = 40°C, T _{Rise} = 110 K, Flange Temperature ≤ 65°C
Motor Controller	Standard winding designed for power supply U _{cc} = 320 or 560 VDC, different execution optional
Flange/Shaft	Acc. To DIN 42955N, optional R



Brushless Servomotors LSN158-xxxx Series



U_{dc} = 560 VDC

General Description:

Compact Design
Rare Earth Magnets
Resolver Feedback
Intercontec-Connectors

Options:

Holding Brake, different Encoders,
Shaft Keyway DIN 6885, UL, ATEX,
spec. Shaft / Flange / Housing,
Gearbox, Flying Leads, etc...

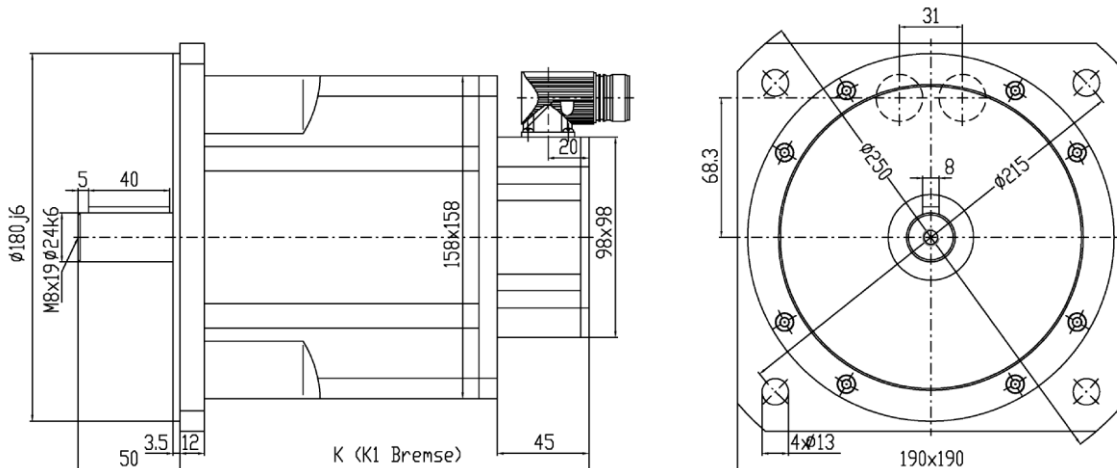

Parameters			LSN158-1800		LSN158-2400		LSN158-3000		LSN158-3800		LSN158-4400	
DC Bus Voltage	U _{dc}	V	560		560		560		560		560	
Rated Torque	M _N	Nm	14,8	13,0	20,0	17,0	25,3	21,0	29,0	25,0	36,5	30,0
Rated AC Current	I _N	A	8,6	11,0	10,7	13,8	12,9	16,2	15,0	19,7	17,3	24,4
Stall Torque	M ₀	Nm	18,0		24,0		30,0		38,0		44,0	
Stall Current	I ₀	A	8,9	12,2	10,8	15,3	12,8	17,8	16,7	23,9	17,7	28,3
Peak Torque	M _{max}	Nm	51		72		90		114		132	
Peak AC Current	I _{max}	A	33	45	42	60	46	64	64	93	64	102
Rated Speed	n _N	min ⁻¹	2000*	3000	2000*	3000	2000*	3000	2000	3000*	2000	3000*
Max. Mech. Speed	n _{max}	min ⁻¹	6000		6000		6000		6000		6000	
Torque Constant	K _T	Nm/A	2,0	1,47	2,2	1,57	2,4	1,69	2,3	1,59	2,5	1,55
Voltage Constant	K _E	V/1000	123	89	134	95	142	102	138	96	150	94
Resistance _{Ph-Ph}	R _{Ph}	Ω	1,19	0,62	0,81	0,41	0,63	0,33	0,52	0,25	0,49	0,19
Inductance _{Ph-Ph}	L _{Ph}	mH	13,7	7,2	10,8	5,5	9,2	4,7	7,2	3,5	7,0	2,8
El. Time Constant	T _{el}	ms	11,5	11,6	13,3	13,4	14,5	14,2	13,8	14,0	14,4	14,5
Therm. Constant	T _{th}	min	42		47		52		57		62	
Inertia	J	kgcm ²	18,5		25,6		32,7		39,9		47,0	
Rated Brake Torque	M _{Br}	Nm	36/72**		36/72**		36/72**		36/72**		36/72**	
Weight w/o brake	m	kg	10,1		12,8		15,5		18,3		21,0	
Weight with brake	m _{Br}	kg	13,2		15,9		18,6		21,4		24,1	
Length w/o brake	K	mm	158		183		208		233		258	
Length with brake	K1	mm	222		247		272		297		322	

*Special Windings; other Windings for different rated Speeds are available; Parameter Tolerance +/-10%; **Reinforced Brake on request

Protection Class	IP64, optional IP65 or IP67
Electrical Connections	Intercontec-Connectors (2 pcs)
Thermal Protection	PTC, optional thermal switch (normally closed type) tripping out at 140°C, KTY or NTC
Rated Parameters	Acc. to EN 60034-1, T _{Ambient} = 40°C, T _{Rise} = 110 K, Flange Temperature ≤ 65°C
Motor Controller	Standard winding designed for power supply U _{cc} = 320 or 560 VDC, different execution optional
Flange/Shaft	Acc. To DIN 42955N, optional R



Brushless Servomotors LSN190-xxxx Series



U_{dc} = 560 VDC

General Description:

Compact Design
Rare Earth Magnets
Resolver Feedback
Intercontec-Connectors

Options:

Holding Brake, different Encoders,
Shaft Keyway DIN 6885, UL, ATEX,
spec. Shaft / Flange / Housing,
Gearbox, Flying Leads, etc...

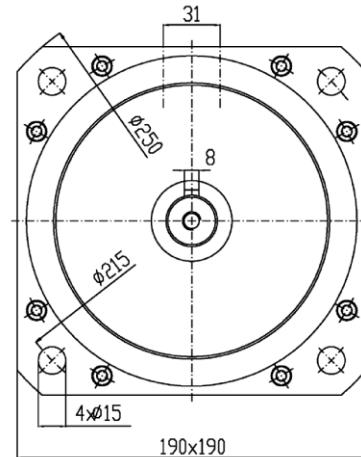
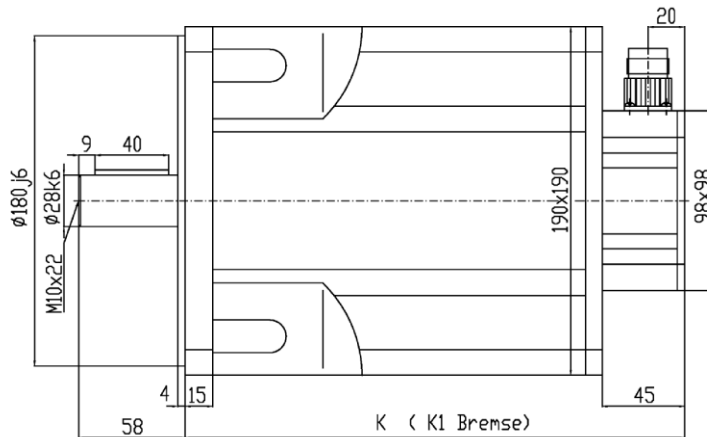

Parameters			LSN190-3000		LSN190-4000		LSN190-5000		LSN190-6000	
DC Bus Voltage	U _{dc}	V	560		560		560		560	
Rated Torque	M _N	Nm	26,1	23,0	32,8	25,0	40,4	30,0	54,0	36,2
Rated AC Current	I _N	A	13,2	15,5	15,4	20,1	21,8	24,4	14,6	20,7
Stall Torque	M ₀	Nm	30,0		40,0		50,0		60,0	
Stall Current	I ₀	A	13,0	16,3	16,7	26,3	22,7	31,5	15,8	30,0
Peak Torque	M _{max}	Nm	85		120		150		180	
Peak AC Current	I _{max}	A	46	58	59	90	79	109	51	102
Rated Speed	n _N	min ⁻¹	2000*	3000	2000	3000*	2000	3000*	1000	2500*
Max. Mech. Speed	n _{max}	min ⁻¹	6000		6000		6000		6000	
Torque Constant	K _T	Nm/A	2,3	1,84	2,4	1,52	2,2	1,59	4,0	2,0
Voltage Constant	K _E	V/1000	139	111	145	92,0	133	96	241	121
Resistance _{Ph-Ph}	R _{Ph}	Ω	0,64	0,41	0,43	0,17	0,25	0,13	0,62	0,16
Inductance _{Ph-Ph}	L _{Ph}	mH	10,1	6,4	7,8	3,1	4,9	2,6	13,0	3,3
El. Time Constant	T _{el}	ms	15,8	15,6	18,1	18,2	19,6	20,0	21,0	21,0
Therm. Constant	T _{th}	min	80		90		100		108	
Inertia	J	kgcm ²	49,5		69,0		88,0		107,0	
Rated Brake Torque	M _{Br}	Nm	36/72**		36/72**		36/72**		36/72**	
Weight w/o brake	m	kg	16,5		21,5		26,5		31,5	
Weight with brake	m _{Br}	kg	20,1		25,1		30,1		35,1	
Length w/o brake	K	mm	181		211		241		271	
Length with brake	K1	mm	240		270		300		330	

*Special Windings; other Windings for different rated Speeds are available; Parameter Tolerance +/-10%; **Reinforced Brake on request

Protection Class	IP64, optional IP65 or IP67
Electrical Connections	Intercontec-Connectors (2 pcs)
Thermal Protection	PTC, optional thermal switch (normally closed type) tripping out at 140°C, KTY or NTC
Rated Parameters	Acc. to EN 60034-1, T _{Ambient} = 40°C, T _{Rise} = 110 K, Flange Temperature ≤ 65°C
Motor Controller	Standard winding designed for power supply U _{cc} = 320 or 560 VDC, different execution optional
Flange/Shaft	Acc. To DIN 42955N, optional R